

Paasche®



HS Model Airbrush

Single Action–External Mix–Siphon Feed Added Bottle Connection

Instruction Manual & Replacment Parts

INTRODUCTION:

Paasche® model HS Airbrush features machined Brass Body and Nickel Silver Color Part, simplicity of design and ease in operation. The air and color feeds are independent and adjustable to give a fixed line, shade or stipple effect.

OPERATING INSTRUCTIONS:

Approximate Working Pressures:

- 20 lbs. or Less: Stipple and granulated effects, pressure will vary with viscosity of fluid.
- 20 to 30 lbs.: Medium consistency water colors, inks & dyes.
- 30 lbs. or More: Heavy fluids, acrylics, reduced lacquers, varnishes, paints or ceramic glaze.

Sizes:

- HS-1 (.45mm)Head and HC-1-3 Aircap for light fluids.
- HS-3 (.64mm)Head and HC-1-3 Aircap for medium fluids.
- HS-5 (1.06mm)Head and HC-5 Aircap for heavier fluids.

1. Attach hose to air supply and allow air to blow a few seconds. Shut off before attaching to Airbrush. This procedure will remove dirt from airline and hose.

Caution: Hold firmly and point away from face.

2. Attach hose coupling to the airbrush.

3. Attach Color Cup or Bottle to HNS-1-3, or 5 Needle by exerting a firm twisting motion to fit tapered tube securely into tapered Needle inlet. Then wrench tighten locking nut.

4. Fill Color Cup or Bottle 1/2 to 3/4 full. Use eyedropper or brush for adding small amounts of color to metal color cup. When using Color Bottle, vent hole must be kept open.

5. To Spray, hold Airbrush like a pencil comfortably between thumb and forefinger using middle finger as a guide and support. Like writing, hold forefinger easily on H-155 Finger Button and Press to open air valve.

6. Regulate volume of color and size of spray by rotating HT-1, 3 or 5 Tip clockwise to increase and counter clockwise to decrease flow of color.

7. Stipple Adjustment: Reducing the airline pressure is the easiest method used when creating a stippled effect with the airbrush. Pressure can be reduced by using any of the following items: 3A Needle Valve installed on the H-128A Valve Casing of the Airbrush or by using the R-75 Air Regulator and reducing the pressure.

8. To adjust for heavier fluids, turn tip wide open, loosen set screw, slide needle back to obtain better flow.

CARE AND CLEANING:

1. Pour any remaining color back into its original container.

2. Wipe Color Cup or Bottle clean, using cloth moistened with proper solvent.

3. Hold Airbrush at a downward angle and put a few drops of solvent through Color Adjusting Part Assembly. To flush out the remaining color in the HS Color Adjusting Part Assembly, apply pressure to the H-155 Finger Button.

4. Apply a tiny dab of Vaseline to the H Color Adjusting Part and HC- Aircap threads every two or three months to prevent color build up and consequent freezing of the Color Adjusting Part Assembly and Aircap.

HOW TO OPEN CLOGGED FLUID PASSAGES:

1. Agitate color in Bottle Assembly by placing finger momentarily over HC- Aircap while air is passing through the Airbrush. This will blow color back into bottle thus opening clogged fluid passages. **Do not do this with a cup as color may blow out of cup.**

2. Should HS-1, 3 or 5 Color Adjusting Part Assembly become clogged, loosen H-153 Set Screw, unscrew HT-1, 3 or 5 Tip from HN Needle, gently pull back through ball-shaped support and remove Tip.

3. Clean Parts carefully, using nothing harder than a wooden toothpick.

4. To reassemble, reverse this procedure, making sure the shoulder of the Needle seats up against ball-shaped support.

5. If the needle and tip are completely clogged, soak in a closed bottle of proper solvent until clean.

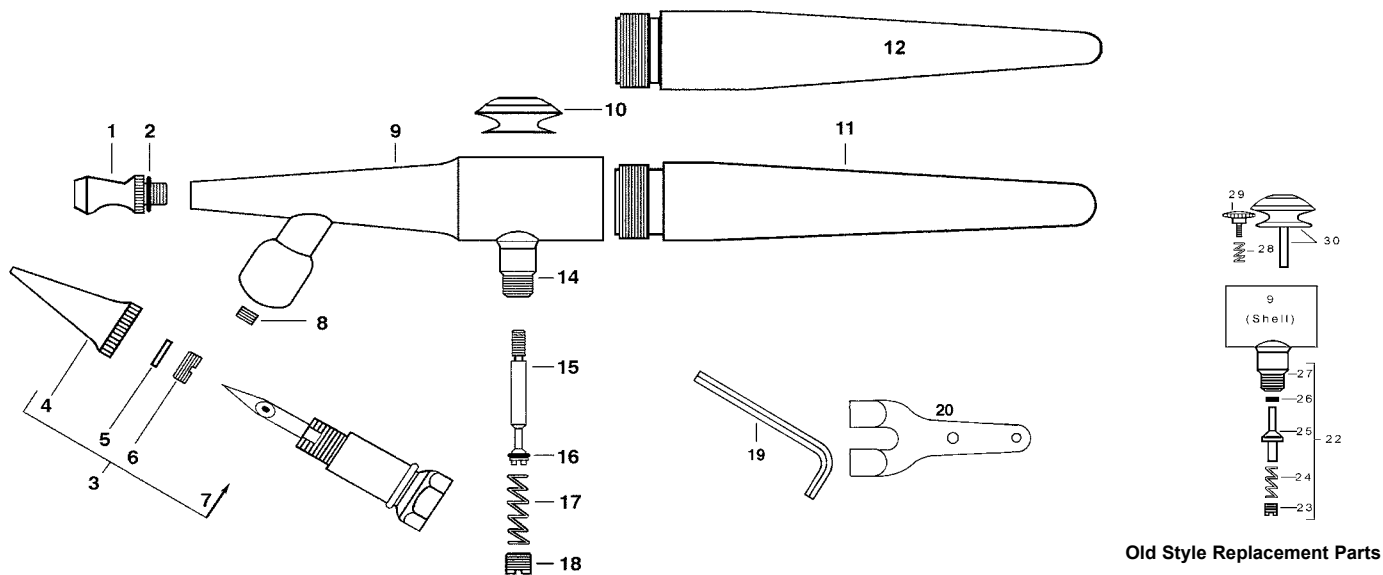

HS - AIRBRUSH MODEL REPLACEMENT PARTS

Part No. Description

- 1. **HC-1-3,5** Aircap w/ O-ring (Select Size)
- 2. **3A-4** "O" Ring (Pack of 6)
- 3. **HS-1,3,5** Color Adjusting Part (Select Size)
- 4. **HT-1,3,5** Tip (Select Size)
- 5. **H-185** Packing
- 6. **H-184** Packing Nut
- 7. **HNS-1-3,5** Needle (Select Size)
- 8. **H-153** Set Screw
- 9. **H-150N** Shell (Includes H-128A)
- 10. **H-155** Finger Button
- 11. **H-143** Handle (Nylon)
- 12. **HVL-200** Metal Handle (Aluminum - optional)
- 14. **H-128A** Valve Casing
- 15. **H-192A** Valve Plunger w/ A-53
- 16. **A-53** Valve Washer (Pack of 6)
- 17. **A-22** Valve Spring
- 18. **A-23R** Air Valve Nut
- 19. **F-186** Wrench
- 20. **A-34** Hanger



Old Style Replacement Parts

HS - Old Style Replacement Parts

- 22. **H-175A** Air Valve Assembly
- 23. **A-23R** Air Valve Nut
- 24. **A-22** Valve Spring
- 25. **H-21A** Valve Plunger
- 26. **A-52** Valve Washer (Pack of 6)
- 27. **H-128A** Valve Casing
- 28. **A-143** Needle Guide Spring
- 29. **H-156** Stipple Adjuster
- 30. **H-157** Finger Lever Assembly

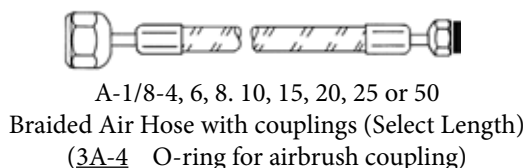

Paasche Airbrush Co.
9511 58th Place Kenosha, WI 53144
Phone:773/867-9191 Email:info@paascheairbrush.com
Website:Paascheairbrush.com

WARNING: Spray materials may be harmful if inhaled or allowed to come into contact with the skin or eyes. Consult the product label and Material Safety Data Sheet supplied for the spray material. Follow all safety precautions. **CAUTION:** Well Ventilated Area Required to remove fumes, dust or overspray. **Maximum Air Pressure 75 P.S.I.**

For Multi-Language Manuals Go To: www.paascheairbrush.com

Available from: Dixie Art Airbrush • www.dixieart.com • 800-783-2612